

SPOTER User Manual

(Version1.1)



Thank you for purchasing the tracker. This manual shows how to operate the device smoothly and correctly. Make sure to read this manual carefully before using this product. Please note that specifications and information are subject to change without prior notice in this manual. Any change will be integrated in the latest release. SPOTER assumes no responsibility for any errors or omissions in this document.

Installation instructions:

Preparation:

- Open the package to check the device model number is correct, be with full Accessories, or else please contact your supplier.
- Choose SIM card, need insert a GSM SIM card into the device, please refer to the suggestion of your supplier for SIM card choice.
- Testing SIM card: to test SIM card, please install it into a normal GSM mobile and ensure it can send and receive SMS, and enables for GPRS.

Notice: Please insert SIM card before turning the device power switch to on; The SIM card need open the GPRS function. Please make sure SIM card with full balance.

Installation area:



SPOTER M2100 VEHICLE TRACKING SYSTEM



Hardware Installation [wiring]:

There are two wires:

- Red wire connect to Battery POSITIVE [+] Pole.
- Black wire connect to Battery NEGATIVE [-] Pole.

Put the device in a safe place, much electric wiring area, meter box can block satellite signal.

Sr.	Description	command
1.	Set Server	SERVER,666666,0, 23.226.141.151,5002,0#
2.	Set APN [Vodafone]	APN,666666,www#
3.	Set APN [Airtel]	APN,666666,airtelgprs.com#
4.	Restart	Reset,666666#
5.	Factory Settings	factory,666666#
6.	Check settings	Param.666666#

If the device not shown in server properly, or show something different :

- Check the FUSE in red wire.
- First Power off the device, Then Power on the Device after 5 minutes.
- Sent restart command through SMS : Reset,666666#
-

After that the fault is not recovered you can do Factory reset by SMS : factory,666666#
Reply from Device SIM : Ok / Factory reset Done.

***** After Factory Setting you have do Software Installation [By SMS] Again.

SPOTER SILVER VEHICLE TRACKING SYSTEM

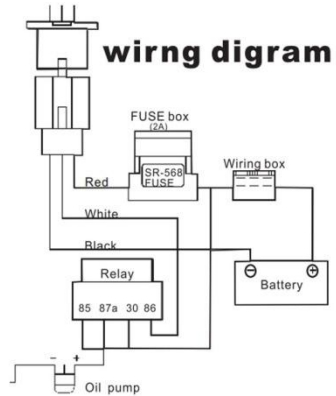

Sr.	Description	command
1.	Set Server	803#23.226.141.151#5002#
2.	Set APN [Vodafone]	802#www#
3.	Set APN [Airtel]	802#airtelgprs.com#
4.	Restart	930#
5.	Factory Settings	940#
6.	Check settings	886#
7.	Add Admin	711#9912345678#
8.	Del Admin	D02#
9.	View Admin	901#
10.	Add Authorized	102#9912345678#
11.	Del Authorized	D12
12.	View Authorized	C10#
13.	Cut power/oil	222#
14.	Supply power/oil	333#
15.	Set power alarm	911#
16.	Set alarm off	910#
17.	Status	902#

SPOTER BRONZE VEHICLE TRACKING SYSTEM

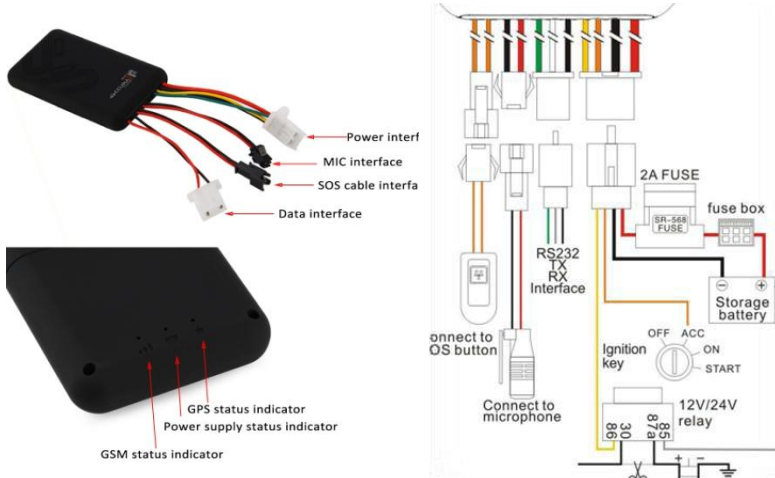

SPOTER SILVER AXA / M2100 AXA VEHICLE TRACKING SYSTEM

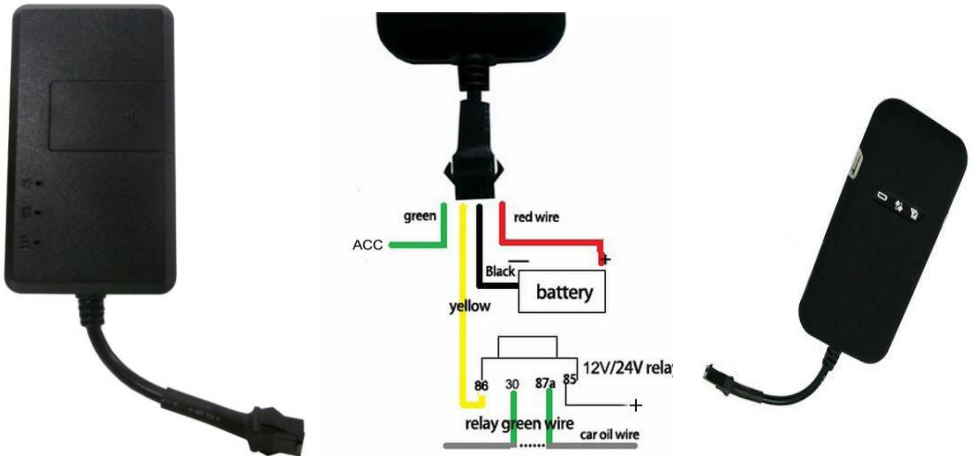

COMMAND LIST FOR BRONZE / SILVER AXA / M2100 AXA VTS

Sr.	Description	command
1.	Start Install	#begin#123456#
2.	Set Server	#ip#123456#23.226.141.151#5023#
3.	Set APN [Vodafone]	#apn#123456#www#
4.	Set APN [Airtel]	#apn#123456#airtelgprs.com#
5.	Restart	#reboot#123456#
6.	Factory Settings	#begin#123456#
7.	Add Admin	#admin#123456#9912345678#
8.	Del Admin	#noadmin#123456#9912345678#
9.	Start Voice Track	#monitor#123456#
10.	Lesion Voice	#call#123456#
11.	Set web Track	#at#30#sum#0#
12.	Start WEB Track	#tracker#123456#
13.	Cut power/oil	#stopoil#123456#
14.	Supply power/oil	#supplyoil#123456#
15.	Status	TCP

- SPOTER BRONZE VTS have voice tracking facility.
- SPOTER M2100 have neither voice tracking facility nor stop oil facility.
- SPOTER SILVER have Remote Stop/supply oil [Remote engine off/On] Facility.

SPOTER GOLD VEHICLE TRACKING SYSTEM WIRING DIAGRAM

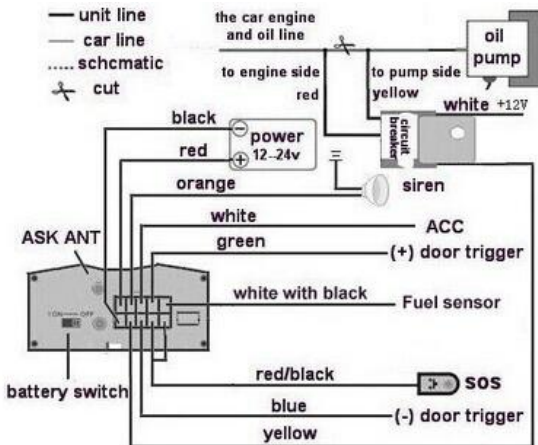

SPOTER GOLD VEHICLE TRACKING SYSYTEM

Sr.	Description	command
1.	Start Install	begin123456
2.	Set Server	adminip123456 23.226.141.151 5001
3.	Set APN [Vodafone]	apn123456 www
4.	Set APN [Airtel]	apn123456 airtelgprs.com
5.	Start GPRS	gprs123456
6.	Less GPRS Traffic	Less gprs123456 on
7.	Fuel PR12 Active	Protocol123456 12
8.	Fuel PR18 Active	Protocol123456 18
9.	Restart	reboot123456
10.	Factory Settings	reset123456
11.	Add Admin	admin123456 9912345678
12.	Del Admin	Noadmin 123456 9912345678
13.	Start Voice Track	monitor123456
14.	Set web Track	Fix030s030m***n123456
15.	Start WEB Track	track123456
16.	Cut power/oil	stop123456
17.	Supply power/oil	resume123456
18.	Status	check123456
19.	Check IMEI	lmei123456
20.	Power alarm on	Extpower123456 on
21.	Power alarm off	Extpower123456 on
22.	Calibration fuel 0	Oilzero123456
23.	Calibration fuel	Oilfull123456

** SPOTER GOLD VTS supports digital fuel sensor.

General Fault Recovery :

If the device not shown in server properly, or show something different:

- Check the FUSE in red wire.
- First Power off the device, Then Power on the Device after 5 minutes.
- Sent restart command through SMS.
- Ring he device sim, if success please reconfigure by sms.

After that the fault is not recovered you can do Factory reset by SMS and reconfigure it by SMS.